



Artilect Smart Motion/Light Sensor

DB122DA3

ARTILECT GREEN

ARTILECT GREEN

ARTILECT GREEN

ARTILECT GREEN

ARTILECT GREEN

ARTILECT GREEN

Features

- DALI Bus input.
- PIR and light sensor – High Bay.
- DALI-2/IEC 62386 303, 304
- Support Smart Link Engine Application Controller.
- Global safety compliant, suitable for home and office.



Artilect Green Co., Ltd.

Tel: +886-2-2597-6188

6F., No. 34-1, Jiuquan St. Datong Dist., Taipei City 10367, Taiwan

<http://www.artilectgreen.com>

Email: info@artilectgreen.com

2. Specification

Technical Data

Model		AGD-DB122DA3
Sensor	Motion	PIR motion sensor, 8m range at 2.5m high.
	Light	1 ~ 65500 lux, sensitive adjustable.
Input	Voltage	DALI Bus
	Current	8mA
Environment	Temperature	-20 ~ +45°C
	Storage	-40 ~ +80°C, 10 ~ 95% Non-condensing
Interface	DALI	DALI-2 IEC 62386 101, 103, 303, 304
Others	Smart Engine	Smart Link Engine
	Dimension	105*45mm
	Accessory	Surface mounting box / Spring clip box

Dimension

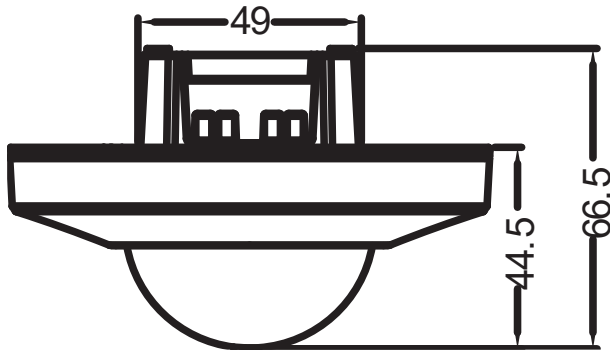

Detection Range

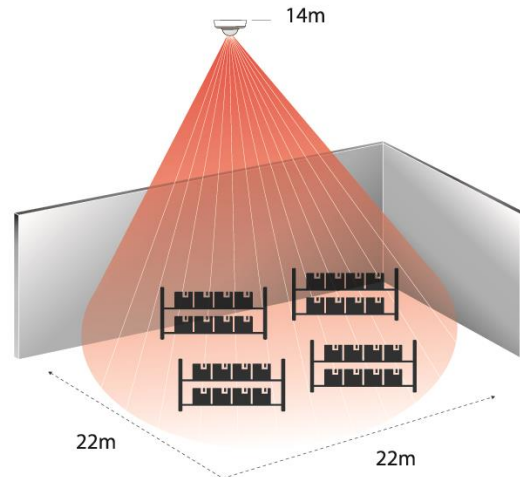

3. Installation

Wiring and circuit diagram

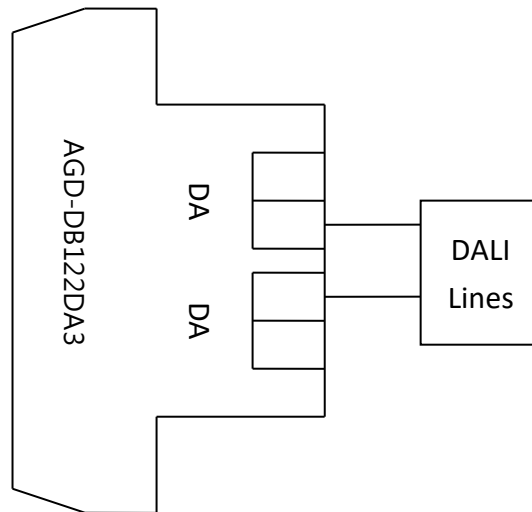

- DA/DA are wires for DALI bus lines. Connect to DALI bus only.
- Please only use DALI-2 certified bus power supplies, and follow the manual of DALI bus installation.
- Please keep the join of cables away from human environment. Double enforcement cables are recommended.

4. Functions

Software

This sensor has equipped Artilect SmartLink Application Controller (Smart Engine). Please refer to its manuals for more information.

5. Others

Warning / Caution !!

- Risk of electrical shock and energy hazard. All failure should be examined by a qualified technician. Please do not remove the case of the device!
- The openings should be protected from foreign objects or dripping liquids.
- Please do not install the device in places with high ambient temperature or

close to fire source. Please refer to the specifications about the maximum ambient temperature limitations.

- If the cases or terminal connector of this device is damaged, it shall be exclusively replaced by the manufacturer or his service agent or a similar qualified person in order to avoid a hazard.
- The DALI is designed as FELV circuit, its terminal shall connect to FELV circuit. Connecting to SELV will lower its isolation level to FELV.