



Smartlink Mini Light Sensor

BL116DA1

ARTILECT GREEN ARTILECT GREEN ARTILECT GREEN ARTILECT GREEN ARTILECT GREEN ARTILECT GREEN

Features

- Mini DALI-2 light sensor: 37x11mm
- DALI bus powered, with 3mA working current
- Adjustable light sensitivity
- SmartLink Application Controller is installed.
- Support smart light adjustor and lux level controller
- IEC 62386 101, 103, 304 compliant
- Global safety compliant
- Suitable for home and office



Artilect Green Co., Ltd.

<http://www.artilectgreen.com>

Tel: +886-2-2597-6188

Email: info@artilectgreen.com

6F., No. 34-1, Jiuquan St. Datong Dist., Taipei City 10367, Taiwan



RoHS

2. Specification

Technical Data

Model		AGD-BL116DA1
Sensor	Max Lux	65534 lux (16 bits resolution), adjustable
	Sensitive	1 ~ 0.01 lux
Input	Voltage	DALI Bus, 10~22.5V, Extended voltage 10~24V
	Current	3mA (typical 2mA)
	Startup Time	1 second
Working Environment	Temperature	-30 ~ +50°C
	Storage	-40 ~ 80°C, 10 ~ 95% Non-condensing
Interface	DALI	DALI IEC 62386 -101 103 304
	Functions	SmartLink Application Controller – Smart Light Adjustor, Lux Level

Dimension

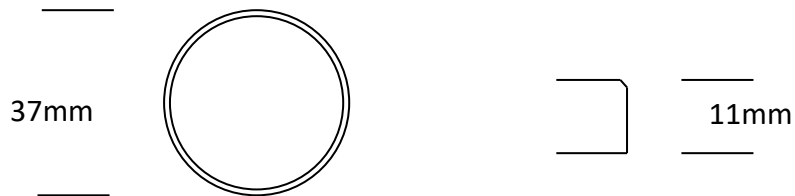

3. Installation

Wiring and circuit diagram

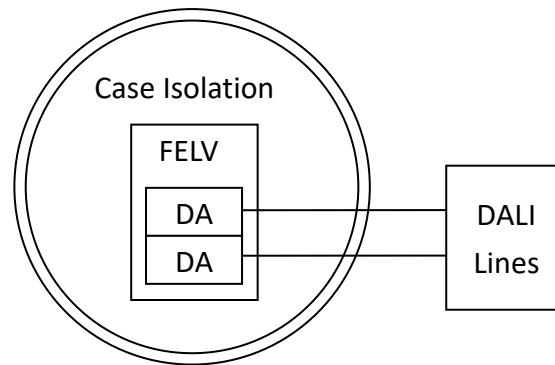

- DA/DA are wires for DALI bus lines. Connect to DALI bus only.
- Please only use DALI-2 certified bus power supplies, and follow the manual of DALI bus installation.
- Please keep the join of cables away from human environment. Double enforcement cables are recommended.

Hot plug-in

You may plug in the device to DALI bus while power-on. However, DALI bus is cataloged as FELV, a good protection glove is strongly advised.

4. Others

Warning / Caution !!

- Risk of electrical shock and energy hazard. All failure should be examined by a qualified technician. Please do not remove the case of the device!
- The openings should be protected from foreign objects or dripping liquids.
- Please do not install the device in places with high ambient temperature or close to fire source. Please refer to the specifications about the maximum ambient temperature limitations.
- If the external flexible cable or cord of this switching power supply is damaged, it shall be exclusively replaced by the manufacturer or his service agent or a similar qualified person in order to avoid a hazard.
- DALI bus lines are cataloged FELV, and this product has designed with 6mm

isolation creeping distance between circuit and gaps.